

the Cu-O(TEMPOL) direction and could not account for a large component parallel to y .

These results seem to indicate that the dipolar contribution alone is not sufficient to explain the experimental \mathbf{D} tensor. We are forced therefore to take into consideration the anisotropic exchange contribution. This is expected to be determined by the spin-orbit mixing of excited states into the ground state. Neglecting low-symmetry components the diagonal elements are given^{16,46} by

$$D_{ii}^{\text{ex}} = J(e_{\text{Cu}}, g_r) \sum_{e_{\text{Cu}}} \frac{|\langle g_{\text{Cu}} | L_{\text{Cu},i} | e_{\text{Cu}} \rangle|^2}{\Delta_{\text{Cu}}^2} \lambda_{\text{Cu}}^2 + J(g_{\text{Cu}}, e_r) \sum_{e_r} \frac{|\langle g_r | L_{r,i} | e_r \rangle|^2}{\Delta_r^2} \lambda_r^2 \quad (3)$$

where $|g\rangle$ and $|e\rangle$ represent the ground and excited state, respectively, r indicates the radical, Δ_{Cu} and Δ_r are the energy differences between the ground and the excited state, λ is the spin-orbit coupling constant, L is the orbital angular momentum operator, and $i = x, y, z$, $J(e, g)$ are the coupling constants between the ground and one excited magnetic orbital. Of the two terms it seems reasonable to consider only the first, since the second depends on the spin-orbit coupling constant on the radical, which is smaller than that of the copper ion.

In order to estimate the possible contribution to \mathbf{D}^{ex} it is convenient to use a slightly idealized symmetry of the Cu-O(TEMPOL) moiety. In particular it is convenient to neglect the small

deviations ($\sim 20^\circ$) of the perpendicular to the nitroxide ring, n , from the bisector of the hfac chelates.²¹ As it is shown in Figure 8 then a very strong π interaction might be operative between the copper xz orbital with ligand p_x orbital containing the unpaired electron. It is therefore conceivable that in eq 3 the dominant term is that relative to $J(xz_{\text{Cu}}, x_r)$. Since xz can be coupled to the ground xy orbital through L_y , eq 3 predicts a large contribution to \mathbf{D} orthogonal to the plane of the π overlap.

If now we go back to the real complex, we can expect that the largest \mathbf{D}^{ex} component will be roughly orthogonal to n , and in fact the largest \mathbf{D} component is observed along the y direction, which makes an angle of 64.8° with n . The deviation may be due to off-diagonal terms which are more difficult to evaluate.

Conclusions

The analysis of the magnetic susceptibility and of the EPR spectra of Cu(hfac)₂(TEMPOL) has confirmed that the extent of coupling of the metal and organic radical spins depends on the relative geometry of the magnetic orbitals localized on the two paramagnetic centers. In particular when the radical ligand occupies axial positions in tetragonally elongated copper(II) complexes the coupling is weak and ferromagnetic. The interactions between excited states of the metal ion and the ground state on the radical have a large influence on both the principal directions and the principal values of the zero-field splitting tensor.

Registry No. Cu(hfac)₂(TEMPOL), 91738-58-8.

Structure and Bonding in Dilithiomethane

Steven M. Bachrach and Andrew Streitwieser, Jr.*

Contribution from the Department of Chemistry, University of California, Berkeley, California 94720. Received December 15, 1983

Abstract: Electron density analysis shows singlet CH₂Li₂ structures to be largely C⁻Li⁺ in character with a small amount of three-center bonding. Three-center bonding is less important for the triplets, which have, instead, significant Li-Li bonding. A simple but effective model of triplet CH₂Li₂ results from excitation of one electron from the HOMO (lone pair) of the singlet into the LUMO (Li-Li bonding) and then allowing relaxation to optimize the geometry and minimize the energy. The anomalous reversed dipole moment of the triplet results from decreased positive charge placed on the lithium atoms due to charge transfer into a Li-Li bonding orbital. To a useful approximation, triplet CH₂Li₂ may be modeled in part as a simple summation of triplet methylene and Li₂. This model aids particularly in explaining the reversal of the dipole moment.

In the search for a planar four-coordinate carbon atom, Collins, Dill, Jemmis, Apeloig, Schleyer, Seeger, and Pople¹ found that lithium was an excellent substituent for stabilizing the planar carbon presumably because of both donor and acceptor characteristics. The simplest molecule with a stabilized four-coordinate planar carbon was found to be dilithiomethane. Four minimum energy structures were obtained—singlet and triplet planar and tetrahedral—with the triplet states of lower energy. The triplet tetrahedral state was of lowest energy, yet the triplet planar state was only 3 kcal mol⁻¹ higher in energy. Since the single determinant Hartree-Fock approximation does not treat singlets and triplets equivalently, the actual ground state was not determined conclusively. However, the indication is clear that the four states are very close in energy.

Schaefer and Laidig² continued this work by fully optimizing the geometry for all four states using a double- ζ -plus polarization (DZ+P) basis set. They found the triplet tetrahedral state to be

only 0.8 kcal mol⁻¹ more stable than the triplet planar state. Inclusion of all single and double excitations gave CI energies which, after being corrected for unlinked clusters, shows the singlet tetrahedral state to be the ground state. However, all four states are within 6 kcal mol⁻¹ of each other. These results are summarized in Table I.

Examination of the optimized structures reveals a few interesting features. The triplet states have significantly longer C-Li bonds and narrower Li-C-Li bond angles than do the singlets. Particularly noteworthy is that the Li-Li distance in the triplets is actually smaller than the Li-Li bond in Li₂ (2.93 Å).³

Perhaps the most remarkable aspects of these systems are their dipole moments. The singlet states have large dipole moments with polarity C⁻Li⁺ as expected, but the triplet states have small dipole moments of opposite polarity, i.e., C⁺Li⁻. The purpose of this work is to determine the nature of the bonding occurring in these systems by use of electron density functions and to rationalize the unusual dipole moments of the triplets.

(1) Collins, J. B.; Dill, J. D.; Jemmis, E. D.; Apeloig, Y.; Schleyer, P. v. R.; Seeger, R.; Pople, J. A. *J. Amer. Chem. Soc.* **1976**, *98*, 5419.

(2) Laidig, W. D.; Schaefer, H. F. III. *J. Am. Chem. Soc.* **1978**, *100*, 5972.

(3) Herzberg, G. "Spectra of Diatomic Molecules", 2nd ed.; Princeton, NJ, Van Nostrand; 1957; p 546.

Table I. Summary of Energy and Dipole Moments of Dilithiomethane

	4-31G ^a <i>E</i> ^d	DZ+P ^b		CI <i>E</i> ^d	6-31G** ^c	
		SCF <i>E</i> ^d	dipole ^e		<i>E</i> ^d	dipole ^e
singlet						
planar	10	3.2	4.85	4.2	7.3	4.59
tetrahedral	0	0.0	5.42	0.0	0.0	5.22
triplet						
planar	-13	-15.8	-1.22	5.9	-16.2	-1.24
tetrahedral	-16	-16.6	-0.76	4.7	-18.2	-0.81

^aCollins et al. ref 1. ^bLaidig and Schaefer, ref 2. ^cThis work. ^dRelative energy in kcal mol⁻¹. ^eDipole moment in debyes with positive direction toward lithium.

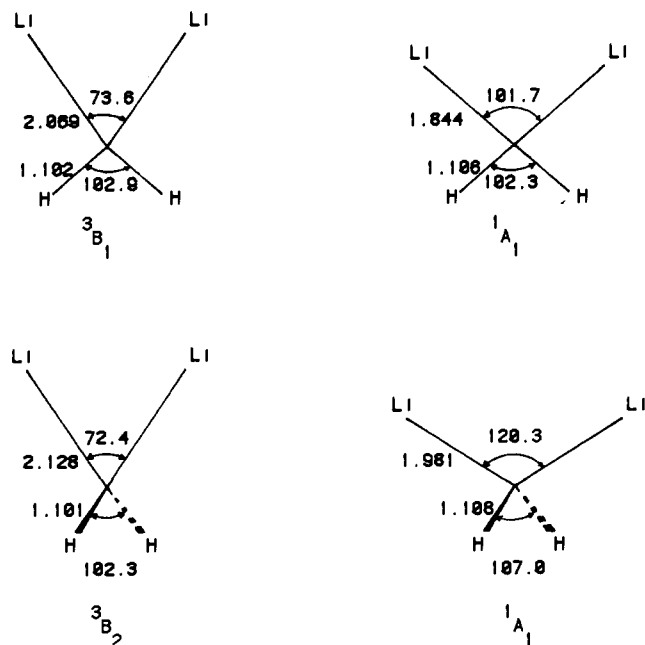

Figure 1. Optimized geometries of the four states of CH₂Li₂ from Laidig and Schaefer.² All bond distances in angstroms and all angles in degrees.

Computational Methods

All calculations were carried out at the 6-31**⁴ level without d functions on lithium. The d exponent of carbon was 0.75, and the p exponent of hydrogen was 1.0. No lithium d functions were used since they have been previously shown to cause insignificant energy or electron density contributions.⁵ The calculations were run on the Lawrence Berkeley Laboratory CDC 7600 using the GAMESS⁶ program or on a VAX 11/750 using a modified^{7a} version of GAUSSIAN 80.^{7b}

The singlets were calculated by using the RHF method, and the triplets were calculated by using the UHF method. Note that in the UHF method all MOs of the α electrons will differ from those of the β . In practice, however, the difference between corresponding α and β MOs is so small that we treat them in terms of doubly occupied MOs in our analysis to compare with the RHF MOs. That is, the 14 UHF singly occupied MOs are discussed in terms of six doubly occupied and two singly occupied MOs.

The PROJ⁸ program was used to calculate projected electron densities used throughout this work. All states were calculated at the geometries determined by Schaefer and Laidig, as shown in Figure 1.

Results and Discussion

The energies and dipole moments determined by using the 6-31** basis set, summarized in Table I, are in excellent agreement with the results of Schaefer and Laidig.² The small discrepancies

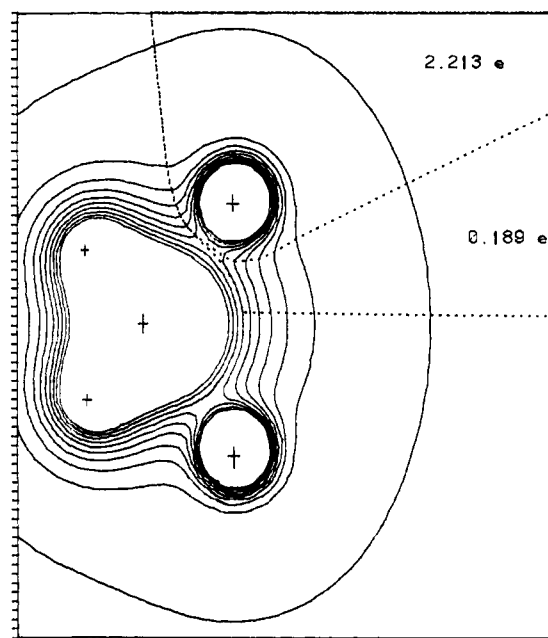

Figure 2. Projected electron density of planar singlet CH₂Li₂ with contour levels from 0.001 to 0.181 by 0.02 e au⁻². Dashed lines indicate two regions of integration for ISEP values given.

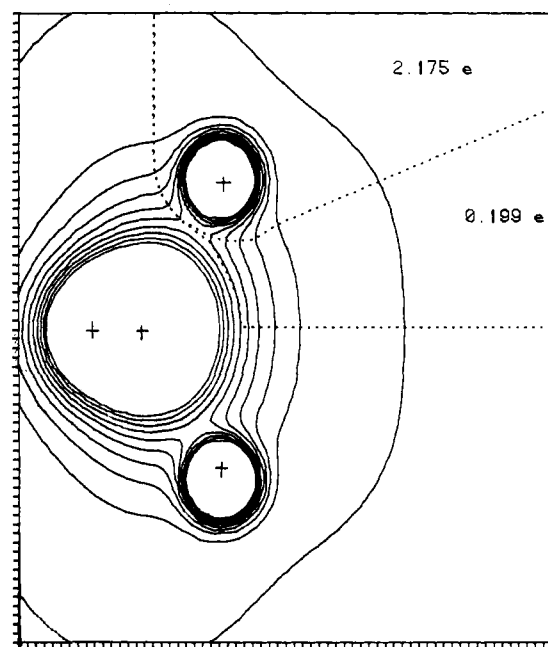

Figure 3. Projected electron density of tetrahedral singlet CH₂Li₂ with contour levels from 0.001 to 0.181 by 0.02 e au⁻². Dashed lines indicate two regions of integration for ISEP values given.

(4) (a) Hehre, W. J.; Ditchfield, R.; Pople, J. A. *J. Chem. Phys.* **1972**, *56*, 2251. (b) Dill, J. D.; Pople, J. A. *Ibid.* **1975**, *62*, 2921.

(5) Graham, G. D.; Marynick, D. S.; Lipscomb, W. N. *J. Am. Chem. Soc.* **1980**, *102*, 4572.

(6) Dupuis, M.; Spangler, D.; Wendoloski, J. J., NRCC No. QG01.

(7) (a) Singh, U. C.; Kollman, P., unpublished results. (b) Binkley, J. S.; Whiteside, R. A.; Krishnan, R.; Seeger, R.; DeFrees, D. J.; Schlegel, H. B.; Topiol, S.; Kahn, L. R.; Pople, J. A. *QCPE* **1981**, *13*, 406.

(8) Streitwieser, A., Jr.; Collins, J. B.; McKelvey, J. M.; Grier, D.; Sender, J.; Toczko, A. G. *Proc. Natl. Acad. Sci. U.S.A.* **1979**, *76*, 2499.

may be accounted for by our use of a slightly smaller basis set. Most important, however, is that the triplet states show reversed

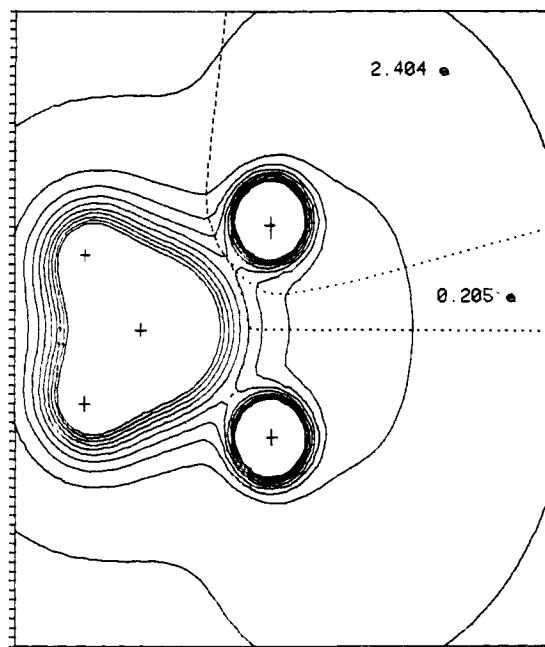

Figure 4. Projected electron density of planar triplet CH_2Li_2 with contour levels from 0.001 to 0.181 by 0.02 e au^{-2} . Dashed lines indicate two regions of integration for ISEP values given.

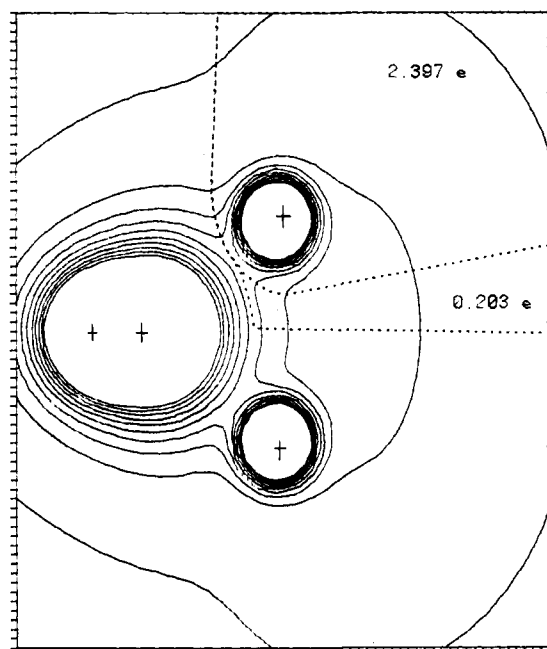

Figure 5. Projected electron density of tetrahedral triplet CH_2Li_2 with contour levels from 0.001 to 0.181 by 0.02 e au^{-2} . Dashed lines indicate two regions of integration for ISEP values given.

dipole moments of the same magnitude for both the 6-31** and DZ+P basis sets, indicating that this phenomenon is not an artifact of the basis set.

Electron densities were determined by projecting the density onto the plane determined by the two lithium atoms and the carbon atom. The maps of the total projected electron density for the four states are given in Figures 2–5. Note that the use of projected densities rather than the density function for a given plane allows for better comparison of planar and tetrahedral structures. Clearly indicated is the shift of electron density toward the lithiums in the triplet cases. There is less electron density between the lithiums and carbon (i.e., along the C–Li bond) in the triplet states than for the singlets.

The greater suitability of projected electron density over Mulliken populations has been argued previously.^{9,10} The pro-

Table II. Electron Population about Lithium

system	Li ISEP		Mulliken	P_{\min}
	virial	bisect		
singlet				
planar	2.213	2.402	2.586	0.128
tetrahedral	2.175	2.374	2.605	0.109
triplet				
planar	2.404	2.609	2.674	0.079
tetrahedral	2.397	2.600	2.695	0.073
${}^3\text{CH}_2 + \text{Li}_2$ model	2.453	2.698		
methyl lithium ^a	2.12			0.10

^a6-31G**, ref 12. ^bMinium value of P along C–Li bond.

jected electron density yields graphical information of the actual distribution of electron density. Mulliken populations assign all electron density present in any given orbital to the atom on which the orbital is centered. Regardless of the spatial extent of the orbital, in effect all Mulliken population electron density is collapsed to the center. For tightly contracted orbitals, this approximation is valid; however, lithium p orbitals have their maximum density at a distance greater than an average C–Li bond length.¹⁰ Some electrons clearly near a carbon atom will be assigned by the Mulliken procedure to lithium, a more distant atom. A concrete example of the failure of Mulliken populations can be witnessed with dilithiomethane. When the net charge of all atoms obtained through Mulliken analysis is used, the predicted dipole moment is calculated for singlet and triplet planar states to be 4.16 and 4.48 D, respectively, compared to the actual values of 4.59 and -1.24 D. Note the complete failure to predict even the correct direction.

The projected electron density maps allow us not only to view the electronic distribution but also to integrate over various regions to determine associated integrated spatial electron populations (ISEP). The lines of demarcation used are shown in Figures 2–5. Results of these integrations about the lithium atom along with the Mulliken populations are summarized in Table II. Two lines of demarcation are used. One is that of the gradient vector that approximates the virial boundary of Bader.¹¹ The correspondence is not exact as our boundary is a vertical curtain rather than a curved surface, but the difference involves regions of relatively low-electron density. When this boundary is used, the integrated spatial electron population (ISEP) for each lithium of the two singlets is 2.18 and 2.21 e or a lithium charge of +0.8. For comparison, the analogous boundary surface for methyl lithium gives an ISEP population about lithium of 2.12.¹² By this criterion, the singlet structures of dilithiomethane are as ionic as methyl lithium and correspond approximately to an ion triplet, $\text{CH}_2^{2-}2\text{Li}^+$. The lithium in the triplets have a higher electron population; their charge is only +0.6.

Figures 2–5 also show alternative demarcation lines which bisect the region between the two lithiums. These boundaries assign a greater effective volume to each lithium, and accordingly the ISEP values are uniformly greater. We believe that these boundaries are less realistic, especially for the singlets. Note that the distance between carbon and the midpoint of the lithium–lithium bond axis is 1.16 Å for the planar singlet and only 0.98 Å for the tetrahedral singlet. These distances are short compared to the normal C–Li bond distance of 2.0 Å. This region between the lithiums surely includes electrons that “belong” to a carbanion pair. Indeed, the projection function contours have a bulge in this region that also suggests that these electrons should be assigned to carbon.

(9) Streitwieser, A., Jr.; Williams, J. E., Jr.; Alexandratos, S.; McKelvey, J. M. *J. Am. Chem. Soc.* **1976**, *98*, 4778.

(10) Streitwieser, A., Jr.; Grier, D. L.; Kohler, A. B.; Vorpagel, E. R.; Schriber, G. W. In “Electron Distributions and the Chemical Bond”; Coppens, P., Hall, M. B., Eds.; Plenum Press: New York, 1982; p 447.

(11) (a) Bader, R. F. W.; Beddall, P. M. *J. Chem. Phys.* **1972**, *56*, 3320.

(b) Bader, R. F. W. *Acc. Chem. Res.* **1975**, *8*, 34.

(12) McDowell, R. S., unpublished results.

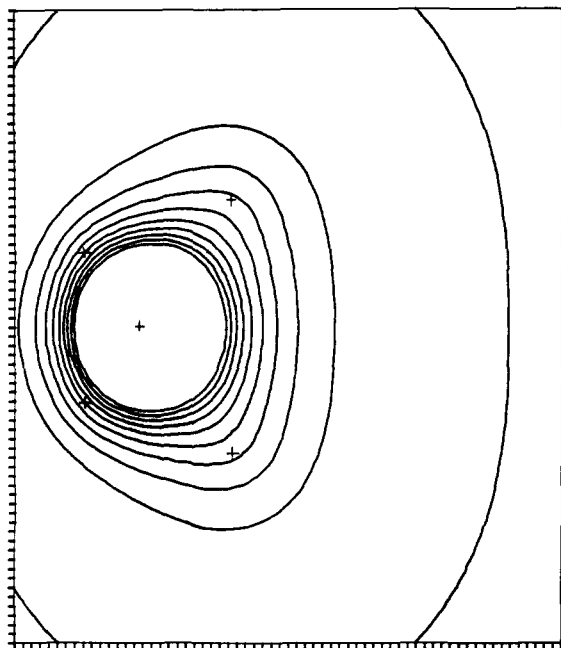

Figure 6. Projected electron density of ϕ_7 (HOMO) of planar singlet CH_2Li_2 with contour levels from 0.0001 to 0.0451 by 0.005 e au^{-2} .

The projection functions along the C–Li bond are also recorded in Table II. The values are all rather small. The lower values for the triplets (0.07, 0.08 e au^{-2}) relative to the singlets (0.13, 0.11 e au^{-2}) reflect the longer C–Li bond length in the triplets and also indicate reduced C–Li shared-electron bonding for the triplets. The values are all comparable to the corresponding minimum for methyl lithium, 0.10 e au^{-2} , which alone suggests that the lithiums do not differ much in this region and that the approximate virial boundary is justified for calculation of ISEPs.

Nevertheless, with any consistent choice of boundary the triplet lithiums are less positive than the singlets. Obviously, the less positive lithiums of the triplets account for their drastically diminished dipole moments. The problem is now to account for more electron density at lithium in the triplets than in the singlets.

Analysis of the bonding in these systems was accomplished by plotting projected electron density for the individual molecular orbitals (MOs). Examination of these maps and the coefficients of the basis functions comprising the individual MOs provides valuable insight.

The singlet cases are formed by doubly occupying the lowest seven molecular orbitals. The projected electron densities of the highest two MOs, ϕ_7 (HOMO) and ϕ_6 (subjacent orbital), of the singlet planar case are depicted in Figures 6 and 7. The HOMO is primarily the lone pair of carbon in and out of the plane (p_y) with a small contribution from Li p_y orbital. The subjacent orbital is the in-phase combination of the carbon p_x orbital with the lithium s orbital. Examination of the coefficients of the basis functions of the LUMO shows this orbital to be constructed of an in-phase combination of the lithium s and p_x orbitals with small contributions from lithium p_y and carbon s orbitals. Schematic drawings of the valence orbitals for the four states are shown in Figure 8. These drawings are constructed directly from the appropriate molecular orbital coefficients by using a program written for the Tektronix 4052A system. Because they emphasize the basis function components of a given MO, these drawings are complementary to the Jorgensen wave function representations in ref 1.

If we approximate the formation of the triplet state by exciting one electron from the HOMO (ϕ_7) of the singlet into its LUMO and then allow the electrons to relax to optimize the energy and geometry, we should find the triplet MOs to be similar to those of the singlet. This is, in fact, the case for dilithiomethane. The highest occupied MOs of the triplet planar state are shown in Figures 9–11. The highest two MOs (ϕ_7 and ϕ_8), Figures 9 and 10, are singly occupied, while the third (ϕ_6) is doubly occupied.

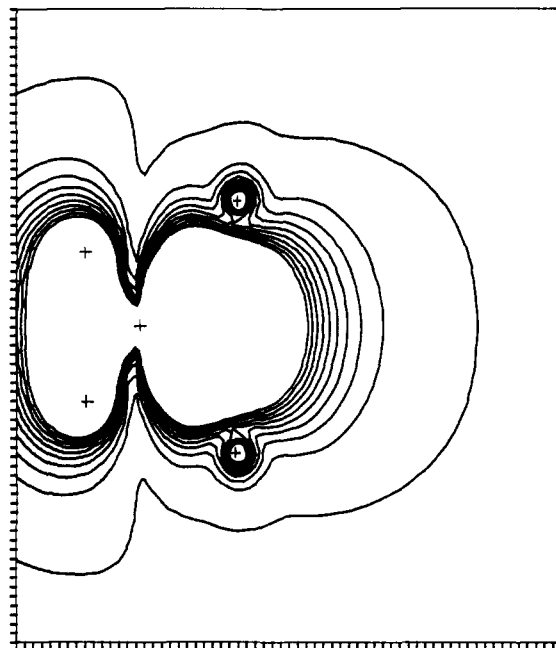

Figure 7. Projected electron density of ϕ_6 (subjacent) of planar singlet CH_2Li_2 with contour levels from 0.001 to 0.0181 by 0.002 e au^{-2} .

Table III. Lithium and Carbon p_y Coefficients of ϕ_7

	6-31G**	6-31** + s,p
Li		
inner	0.205	0.190
outer	0.071	0.004
C		
inner	0.401	0.404
outer	0.439	0.406
diffuse		0.177

The doubly occupied orbital ϕ_6 (Figure 11) shows carbon p_x and lithium p_x and s character as in the subjacent orbital (ϕ_6 , Figure 7) of the singlet. The subjacent orbital of the triplet (ϕ_7 , Figure 10) is primarily the carbon p_y , exactly the same as the HOMO of the singlet (Figure 6). Most convincing for this hypothesis is the shape of the triplet planar HOMO (Figure 9). It is constructed of lithium p_x and s orbitals in a bonding fashion with antibonding carbon s character, exactly as predicted by the LUMO of the singlet (see Figure 8).

The same argument applies to the tetrahedral case as well. Of particular interest is the HOMO of the tetrahedral triplet shown in Figure 12. It is constructed from lithium p_z and s orbitals in a bonding manner with an antibonding carbon s component, which are also the major components of the singlet tetrahedral LUMO. The planar and tetrahedral triplet HOMOs (Figures 9 and 12) are virtually identical.

We can thus deduce the nature of the bonding occurring in the valence region. For the planar cases, the single HOMO and the subjacent orbital of the triplet have been interpreted as evidence of three-center bonding.¹ Clearly, there is electron density spread from the lone pair of carbon toward both lithium atoms; however, this distortion is rather small. It is well established¹³ that anions require diffuse s and p functions for adequate description. Dilithiomethane clearly has an anionic carbon with the anionic character localized to the p_y orbital. These electrons require large space in which to delocalize to reduce their mutual repulsion and may be using lithium p functions not to describe bonding but rather to aid the description of the anion itself. In other words, lithium p functions may be acting as superposition functions, not as valence or polarization functions.¹⁴ To test this possibility, planar

(13) Chandrasekhar, J.; Andrade, J. G.; Schleyer, P. v. R. *J. Am. Chem. Soc.* 1981, 103, 5609, 5612.

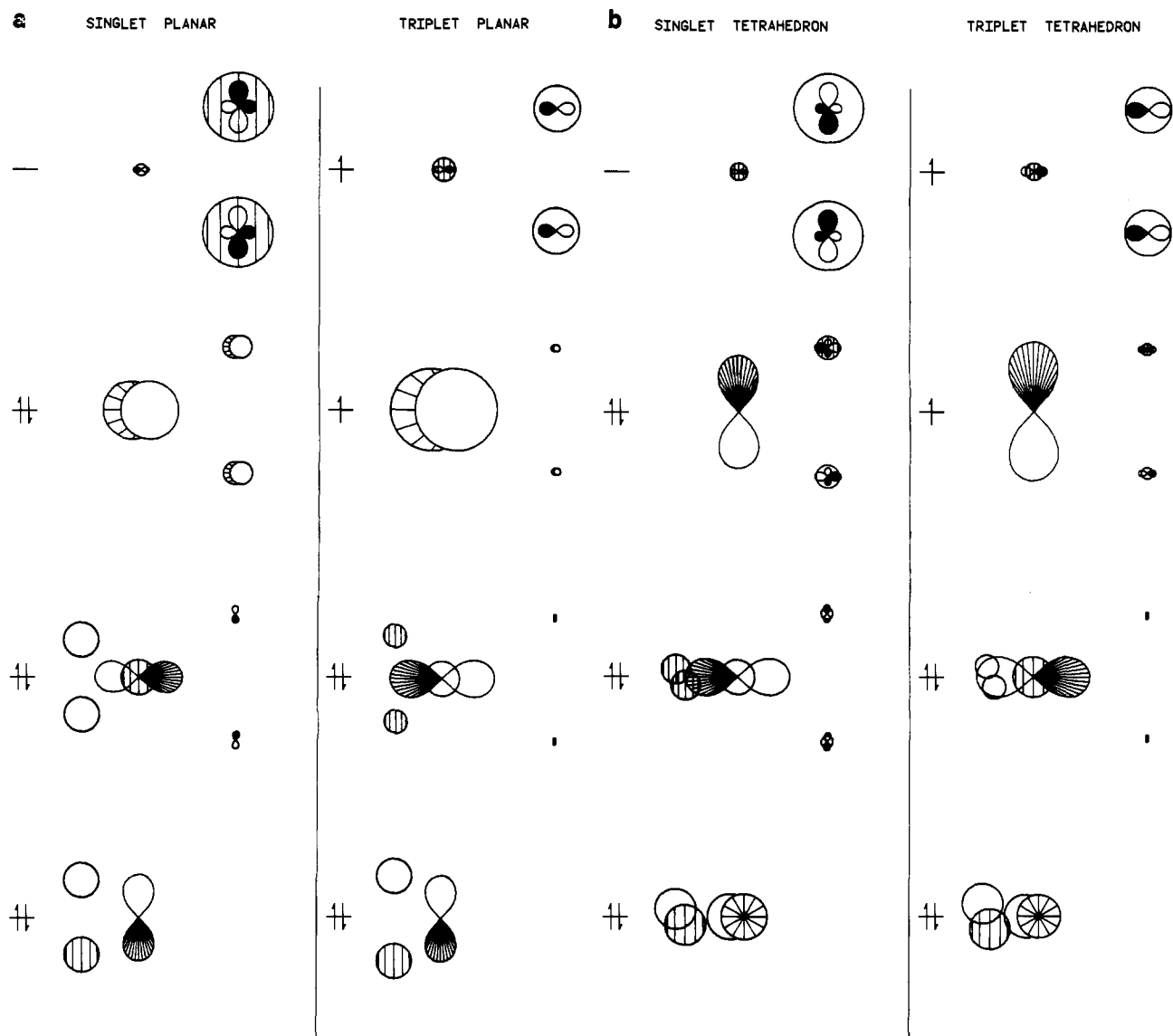

Figure 8. Schematic representation of the MOs of singlet and triplet CH_2Li_2 . (a) Planar, (b) tetrahedral.

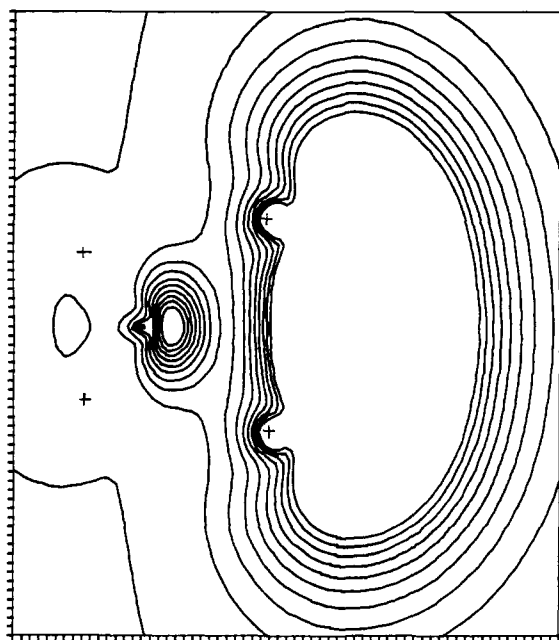

Figure 9. Projected electron density of ϕ_8 (HOMO) of planar triplet CH_2Li_2 with contour levels from 0.0001 to 0.0091 by 0.001 $e \text{ au}^{-2}$.

singlet dilithiomethane was calculated by using the 6-31** basis set supplemented with a diffuse s and p shell (exponent of 0.04¹³). Table III lists the coefficients of the carbon and lithium p_y functions for both basis sets. Addition of these diffuse functions causes a slight drop in the coefficient of the inner lithium p_y , but reduces the outer coefficient to almost zero (0.004). The relatively large coefficient of the diffuse carbon p_y function indicates that the anionic center requires diffuse space to be well described. Clearly, the dramatic decrease of the outer lithium p_y coefficient indicates that it was indeed used in the 6-31** case as a superposition function. We emphasize that the outer lithium p functions are well suited to be used as superposition functions because they are so diffuse.^{10,14} On the other hand, the inner lithium p_y function has a substantial coefficient even with the diffuse s and p shell, indicating that it is being used to form a weak, but distinct, three-center bond. It should be noted that the addition of diffuse functions to an already large basis set (almost DZ+P) is not expected to have a large effect, yet the energy decreases by 2.47 kcal mol⁻¹. Thus, the Hartree-Fock limit had not been approached.

Nevertheless, the basis set variations as used here provide an interesting criterion for bonding. For example, incomplete charge transfer in an ionic structure involving dilithium would result in

(14) Bachrach, S. M.; Streitwieser, A., Jr. *J. Am. Chem. Soc.* **1984**, *106*, 2283-2287.

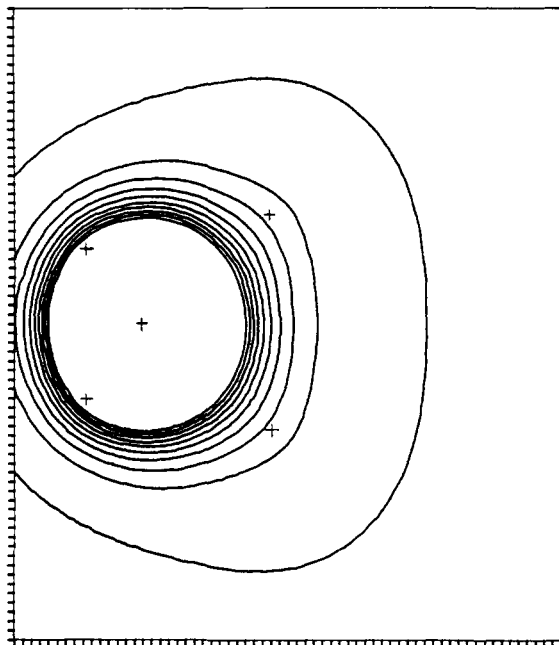

Figure 10. Projected electron density of ϕ_7 (subadjacent) of planar triplet CH_2Li_2 with contour levels from 0.0001 to 0.0091 by 0.001 e au^{-2} .

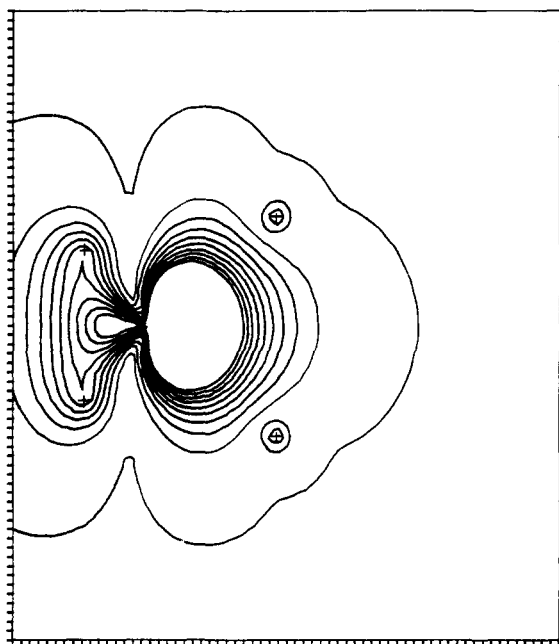

Figure 11. Projected electron density of ϕ_6 of planar triplet CH_2Li_2 with contour levels from 0.0001 to 0.0451 by 0.005 e au^{-2} .

primarily excess Li s population. Polarization of electron density toward the anion would utilize the p orbital directed toward the anion. Utilization of the perpendicular p orbital must be either as superposition or bonding functions. Since superposition has been evaluated as involving primarily the Li outer p_y orbital, the use of the inner Li p_y orbital mentioned above must represent a chemically bonding function.

It should also be noted that the degree of three-center bonding in ϕ_7 is greater in the singlet than the triplet. This is best evidenced by determining the first contour line which just encompasses all three centers. For the singlet this is the 0.02 contour, and for the triplet this is the 0.002 contour. Correcting for the fact that ϕ_7 of the triplet is only singly occupied, the singlet case still has more electron density about the centers than the triplet by a factor of about five.

The triplet HOMO (ϕ_8) decidedly has a Li-Li bond, which is formed of an in-phase combination of s and p_z orbitals with minor

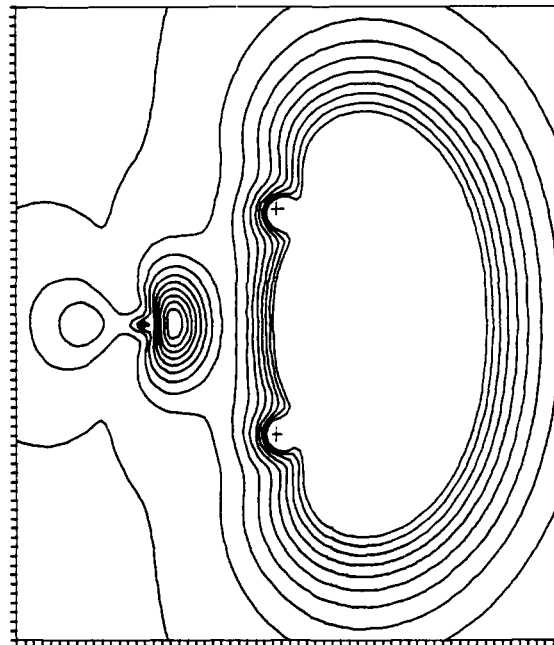

Figure 12. Projected electron density of ϕ_8 (HOMO) of tetrahedral triplet CH_2Li_2 with contour levels from 0.0001 to 0.0091 by 0.001 e au^{-2} .

in-phase overlap of p_x . The HOMO of the tetrahedral triplet also demonstrates this large Li-Li bond character. Note particularly that the small carbon s contribution to the HOMO of each triplet case is antibonding. We can explain the greatly lengthened C-Li bond of the triplet on the basis that the triplet HOMO expresses partial C-Li antibond character, thereby weakening the C-Li attraction occurring in the now singly occupied pseudo-three-center Li-C-Li orbital. The Li-Li bond character of the triplet HOMO also accounts for bringing the lithiums closer together than in the singlet. Since all C-H bonding in the lower orbitals is so similar in the different states, the C-H bond lengths and H-C-H angles do not vary significantly between the electronic states.

The difference in dipole moments between singlets and triplets arises primarily from the excitation of a single HOMO electron of the singlet into its LUMO to form the triplet. Since the HOMO of both singlets is perpendicular and symmetric to the axis of the dipole, any electron in the HOMO will not significantly affect the dipole moment. Thus, the act of removing the electron from the HOMO itself will not significantly affect the dipole moment. However, this electron is then placed in an orbital which lies about the two lithiums and thereby decreases the positive charge on the lithiums. This may be thought of as a charge transfer from an orbital playing no role in determining the dipole moment to a Li-Li bonding orbital. Since only one electron is involved in such charge transfer, the carbon is still partially carbanionic and the lithiums are partially cationic; bonding between C and Li is still largely ionic.

The fact that the triplet HOMO has a Li-Li bond suggests that triplet dilithiomethane may be modeled in part as triplet methylene associated with Li_2 .¹⁵ Triplet methylene and Li_2 were calculated individually by using the same basis as before. Their wave functions were then summed together, placing the atoms at the geometry of triplet tetrahedral dilithiomethane. The projected electron density of this model is given in Figure 13. The region about a lithium atom was integrated by using the same lines of demarcation as for triplet tetrahedral dilithiomethane. An interesting feature is how well this line accounts for the density about lithium for the summation model. The integrated population at lithium is only 0.05–0.1 e greater in the model than for the actual triplet tetrahedral case. The result is to be expected because triplet

(15) Janoschek, R. In "Excited States in Organic Chemistry and Biochemistry"; Pullmann, B., Goldblum, N., Eds.; Reidel: Dordrecht, Holland, 1977; pp 419–429.

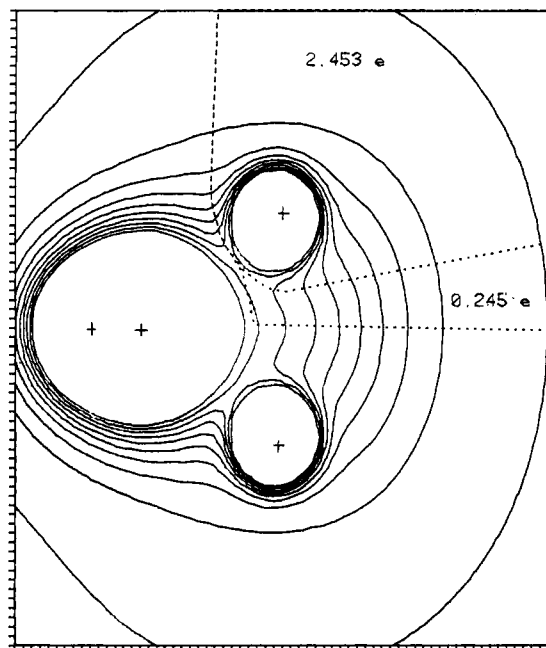

Figure 13. Projected electron density of the summation of Li_2 and triplet methylene with contour levels from 0.001 to 0.091 by 0.01 e au^{-2} . Dashed line is the demarcation line for tetrahedral triplet CH_2Li_2 .

dilithiomethane with one electron in a Li-Li bonding orbital is being compared with a model having a two-electron Li-Li bond. Nevertheless, the model greatly assists in explaining the reversed dipole moment of the triplets. Triplet methylene has a dipole

moment of 0.66 D with the hydrogen end being positive. Thus, the decrease of the positivity of the lithiums in the triplet state allows for the inherent dipole of triplet methylene to become significant, enough so as to actually reverse the direction of the dipole moment of dilithiomethane.

For a similar system, 1,1-dilithioethylene, a dipole moment reversal has been noted for the planar triplet and tetrahedral triplet states.¹⁶ Their argument for explaining increased electron density about lithium in the triplets is similar to ours. However, it is not clear that a Mulliken population difference of 0.13 e between the singlet and the triplet is both an accurate expression of the electron population about lithium or sufficient for reversing the dipole moment. Triplet 1,1-dilithioethylene may be modeled as triplet vinylidene associated with Li_2 (analogous to our model for dilithiomethane). The inherent dipole moment of vinylidene is 0.43 D with the hydrogen end positive. Therefore, the dipole moment may reverse in the same fashion as for dilithiomethane; i.e., a decreased positivity of lithium allows the dipole moment contribution of triplet vinylidene to become dominant.

Acknowledgment. Preliminary calculations were done by G. W. Shriver. This research was supported in part by N.I.H. Grant No. GM-30369. The VAX 11/750 used in this work was purchased in part by N.S.F. equipment Grant No. CHE-8214313.

Registry No. CH_2Li_2 , 21473-62-1.

(16) (a) Laidig, W. D.; Schaefer, H. F., III. *J. Am. Chem. Soc.* **1979**, *101*, 7184. (b) Apeloig, Y.; Schleyer, P. v. R.; Binkley, J. S.; Pople, J. A. *Ibid.* **1976**, *98*, 4332.

Symmetry Aspects of Jahn-Teller Activity: Structure and Reactivity

A. Ceulemans,* D. Beyens, and L. G. Vanquickenborne*

Contribution from the Department of Chemistry, University of Leuven, 3030 Heverlee, Belgium.
Received April 13, 1983

Abstract: The Jahn-Teller theorem predicts that highly symmetrical molecules with a degenerate ground state are subject to distorting forces, acting along certain nontotally symmetric vibrational modes. These vibrations carry the nuclei over into distorted configurations, corresponding to subgroup symmetries of the parent molecular point group. The group-theoretical concepts of kernel and epikernel are of immediate relevance in this respect, since they can be shown to describe respectively the lowest subgroup attainable and the allowed intermediate subgroups. Moreover a general epikernel principle can be proposed: stationary points on a Jahn-Teller potential surface will adopt epikernel rather than kernel symmetries; higher ranking epikernels are preferred over lower ranking epikernels. By a straightforward assignment of the relevant extremal points, this principle greatly simplifies the various theoretical methods that describe potential energy surfaces near a Jahn-Teller unstable origin. In addition, the kernel and epikernel concepts offer a very concise expression of the McIver-Stanton reaction rules. The topological implications of the Jahn-Teller theorem can thus be fully explored. The present work avoids abstract terms; instead, the paper is conceived as a case study of the $T \times (t_2 + e)$ problem. Several examples relating to the structure and reactivity of metal carbonyl molecular fragments are included. In these examples the signs of the vibronic coupling constants have been obtained by a generalization of Bacci's angular overlap model treatment.

I. Introduction

The usual procedure to predict molecular shapes is to carry out a set of numerical calculations on selected geometries and to retain the one that yields an absolute minimum.¹⁻³ Such calculations often explore only a minute part of the Born-Oppenheimer hypersurface and may fail to elucidate the general topological

structure of that surface. This structure can hardly be obtained by point-to-point calculations. Rather, what is required is an understanding of the hyperplane's geometry and its general symmetry properties.⁴

In some cases, a useful starting point is provided by the Jahn-Teller (JT) theorem, especially in its perturbational form as described by Opik and Pryce.⁵ It applies whenever the surface

(1) Elian, M.; Hoffmann, R. *Inorg. Chem.* **1975**, *14*, 1058.
(2) Burdett, J. K. *J. Chem. Soc., Faraday Trans. 2* **1974**, *70*, 1599.
(3) Burdett, J. K. "Molecular Shapes"; Wiley: New York, 1980.

(4) Pearson, R. "Symmetry Rules for Chemical Reactions"; Wiley: New York, 1976.